

Quiz 7 Preparation Ch 7.1, 7.2, & 7.3 v02

There will be EIGHT questions chosen from below.

No Book/No Notes/No Ipod/No Phone/Yes Calculator 20 minutes

Name \_\_\_\_\_

Sketch the graph of the function. Give the coordinates of the vertex.

1)  $f(x) = (x + 6)^2$

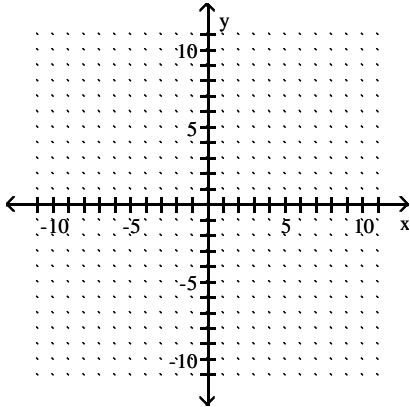

2)  $f(x) = x^2 + 1$

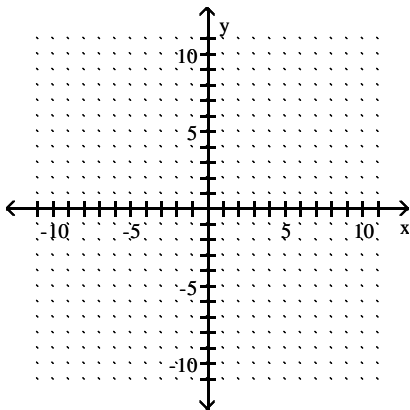

3)  $f(x) = -x^2 + 5$

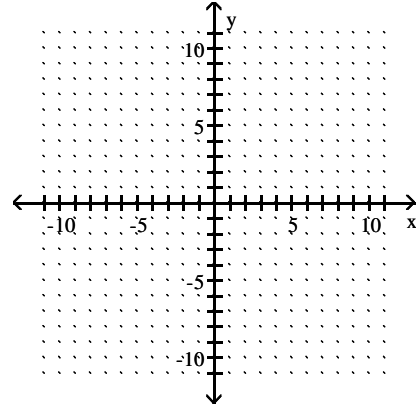

4)  $f(x) = 3(x - 1)^2 + 6$

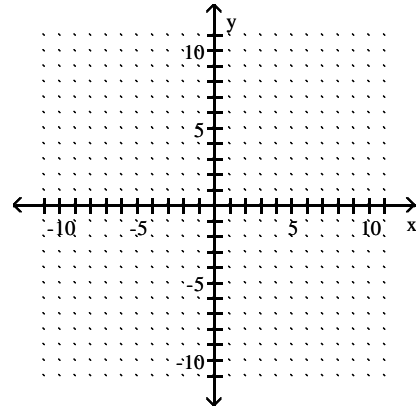

$$5) f(x) = -\frac{1}{5}(x+5)^2 + 4$$

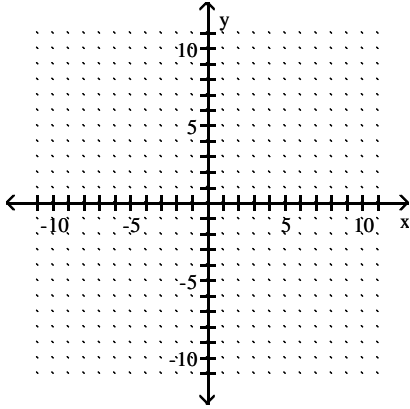

$$7) f(x) = -(x+1)^2 + 4$$

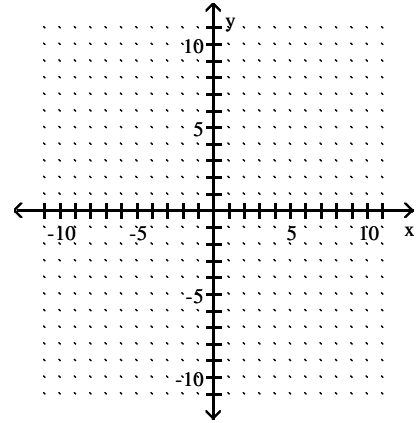

$$6) f(x) = -(x-6)^2$$

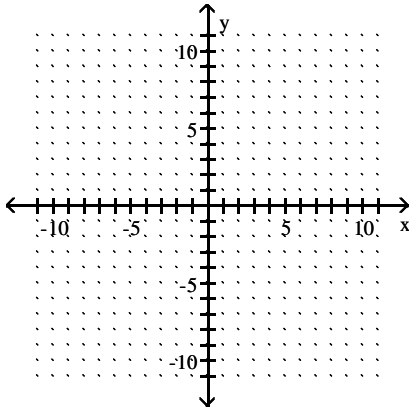

$$8) f(x) = -(x-1)^2 + 4$$

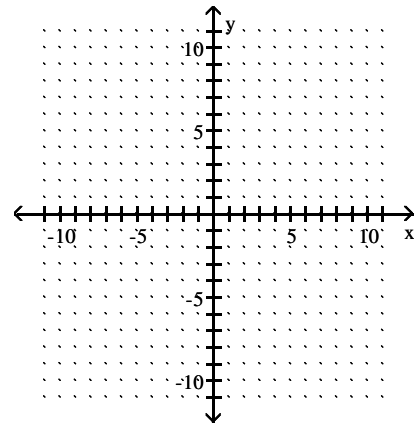

Sketch the graph of the function and find the domain and range.

9)  $f(x) = x^2 - 1$

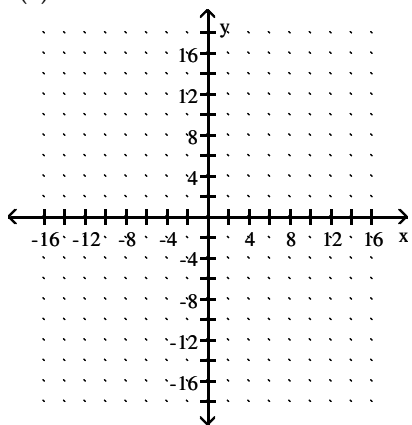

10)  $f(x) = x^2 + 1$

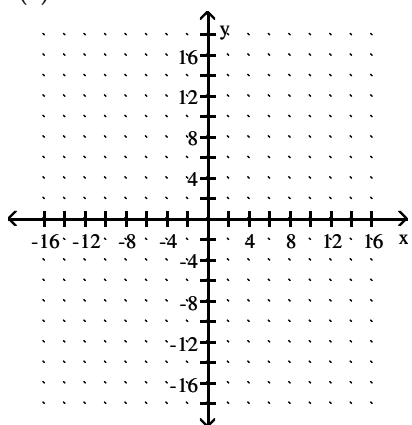

11)  $f(x) = (x + 2)^2 + 3$

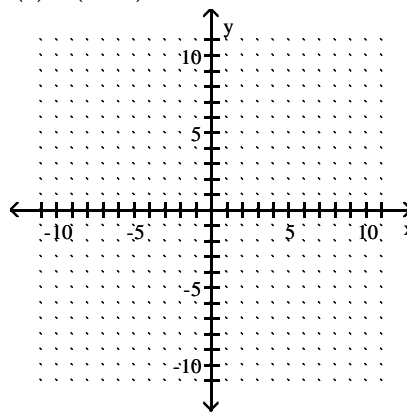

12)  $f(x) = -x^2 + 3$

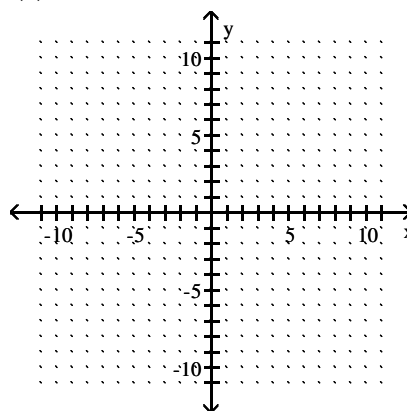

**Solve the problem.**

- 13) Find an equation of the function  $f$  sketched below in the form  $f(x) = a(x - h)^2 + k$ . Use the vertex to find the values of  $h$  and  $k$  and use a second point on the graph to find the value of  $a$ .

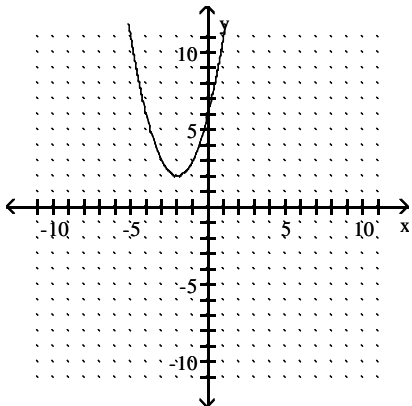

- 14) Find an equation of the function  $f$  sketched below in the form  $f(x) = a(x - h)^2 + k$ . Use the vertex to find the values of  $h$  and  $k$  and use a second point on the graph to find the value of  $a$ .

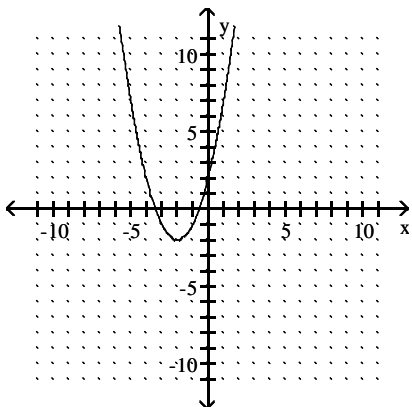

- 15) Find an equation of the function  $f$  sketched below in the form  $f(x) = a(x - h)^2 + k$ . Use the vertex to find the values of  $h$  and  $k$  and use a second point on the graph to find the value of  $a$ .

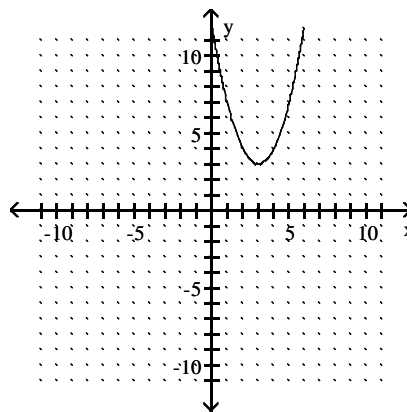

- 16) Find an equation of the function  $f$  sketched below in the form  $f(x) = a(x - h)^2 + k$ . Use the vertex to find the values of  $h$  and  $k$  and use a second point on the graph to find the value of  $a$ .

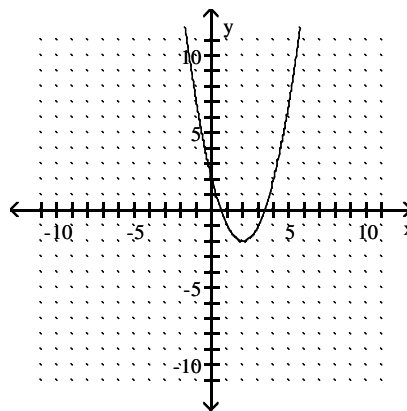

Find the vertex, the y-intercept, and the x-intercepts (if any exist), and graph the function.

17)  $y = x^2 - 2x - 8$

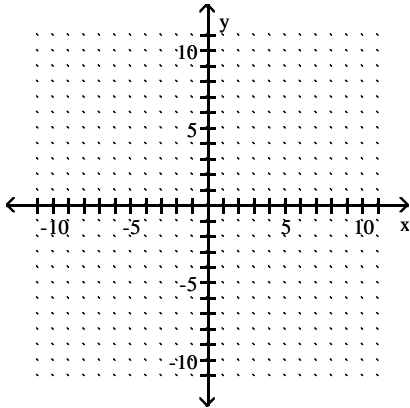

19)  $y = -x^2 - 4x - 4$

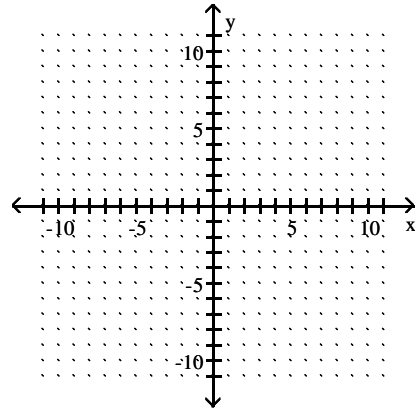

18)  $y = -10x^2 - 20x$

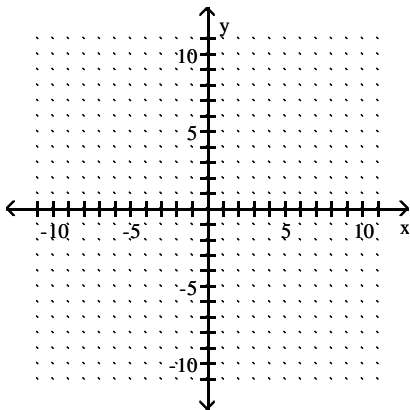

20)  $y = x^2 - 64$

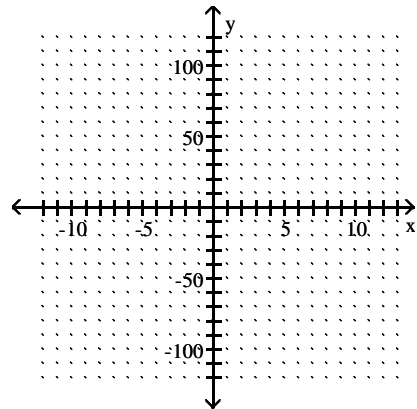

**Solve the problem.**

- 21) April shoots an arrow upward into the air at a speed of 32 feet per second from a platform that is 23 feet high. The height of the arrow is given by the function  $h(t) = -16t^2 + 32t + 23$ , where  $t$  is the time in seconds. What is the maximum height of the arrow?
- 22) An object is propelled vertically upward from the top of a 304-foot building. The quadratic function  $s(t) = -16t^2 + 144t + 304$  models the ball's height above the ground,  $s(t)$ , in feet,  $t$  seconds after it was thrown. After how many seconds does the object reach its maximum height? Round to the nearest tenth of a second if necessary.
- 23) A developer wants to enclose a rectangular grassy lot that borders a city street for parking. If the developer has 260 feet of fencing and does not fence the side along the street, what is the largest area that can be enclosed?
- 24) A rain gutter is made from sheets of aluminum that are 18 inches wide by turning up the edges to form right angles. Determine the depth of the gutter that will maximize its cross-sectional area and allow the greatest amount of water to flow.
- 25) The cost in millions of dollars for a company to manufacture  $x$  thousand automobiles is given by the function  $C(x) = 3x^2 - 24x + 144$ . Find the number of automobiles that must be produced to minimize the cost.
- 26) The cost in millions of dollars for a company to manufacture  $x$  thousand automobiles is given by the function  $C(x) = 3x^2 - 30x + 175$ . Find the number of automobiles that must be produced to minimize the cost.
- 27) The daily profit in dollars of a specialty cake shop is described by the function  $P(x) = -6x^2 + 312x - 3192$ , where  $x$  is the number of cakes prepared in one day. The maximum profit for the company occurs at the vertex of the parabola. How many cakes should be prepared per day in order to maximize profit?
- 28) The owner of a video store has determined that the profits  $P$  of the store are approximately given by  $P(x) = -x^2 + 120x + 71$ , where  $x$  is the number of videos rented daily. Find the maximum profit to the nearest dollar.

**Simplify.**

$$29) \sqrt{\frac{100}{81}}$$

$$30) \sqrt{\frac{2}{13}}$$

$$31) \sqrt{\frac{20}{289}}$$

$$32) \sqrt{\frac{5}{36}}$$

$$33) \frac{5}{\sqrt{2}}$$

**Solve.**

$$34) (x + 5)^2 = 2$$

$$35) (x - 6)^2 = 49$$

$$36) (2x - 3)^2 = 81$$

$$37) (x + 3)^2 = 24$$

$$38) (2x + 3)^2 = 5$$

$$39) \left(x - \frac{5}{2}\right)^2 = \frac{121}{4}$$

$$40) \left(x + \frac{3}{2}\right)^2 = \frac{7}{4}$$

**Find all complex number solutions.**

$$46) x^2 = -25$$

$$41) 5(y - 1)^2 + 11 = 92$$

$$47) x^2 + 81 = 0$$

$$42) (m + 3)^2 - 12 = 37$$

$$48) 3x^2 = -49$$

$$43) (m + 4)^2 - 12 = 37$$

$$49) (x - 12)^2 = -25$$

$$44) (m + 4)^2 - 10 = 39$$

$$50) \left(x + \frac{5}{4}\right)^2 = -\frac{6}{16}$$

$$45) (6x - 3)^2 - 3 = -2$$

$$51) -5(y - 1)^2 + 13 = 49$$

# Answer Key

Testname: QUIZ 7PREPARATION CH 7.1, 7.2, & 7.3V02

1) vertex  $(-6, 0)$

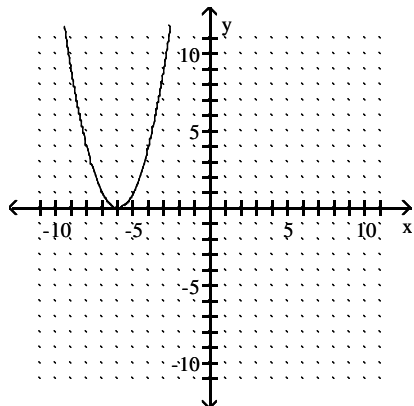

2) vertex  $(0, 1)$

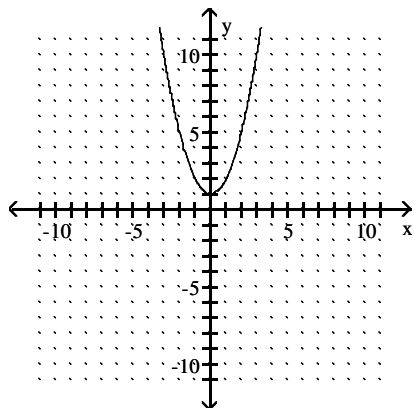

3) vertex  $(0, 5)$

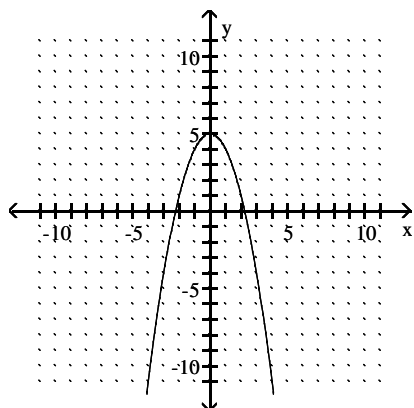

Answer Key

Testname: QUIZ 7PREPARATION CH 7.1, 7.2, & 7.3V02

4) vertex (1, 6)

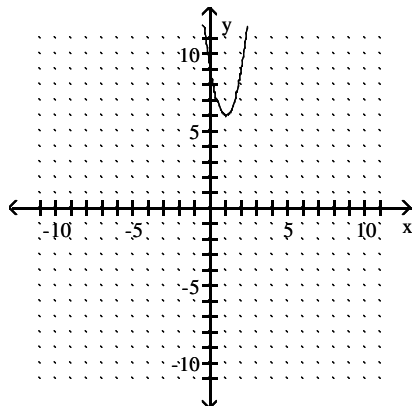

5) vertex (-5, 4)

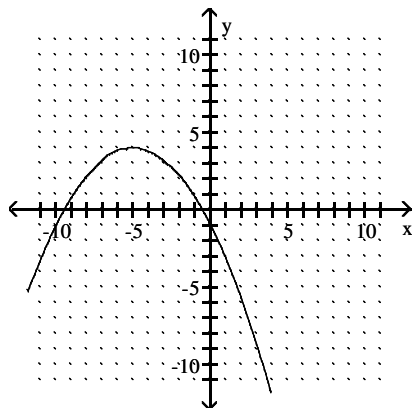

6) vertex (6, 0)

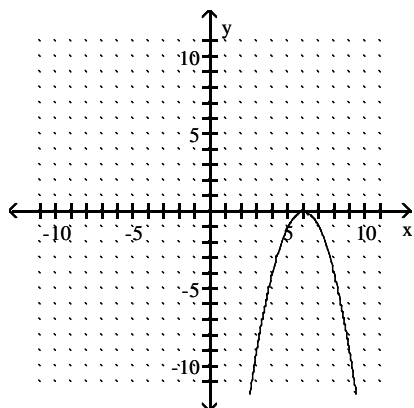

Answer Key

Testname: QUIZ 7PREPARATION CH 7.1, 7.2, & 7.3V02

7) vertex:  $(-1, 4)$

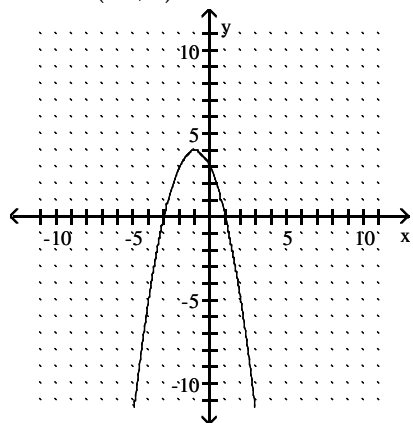

8) vertex:  $(1, 4)$

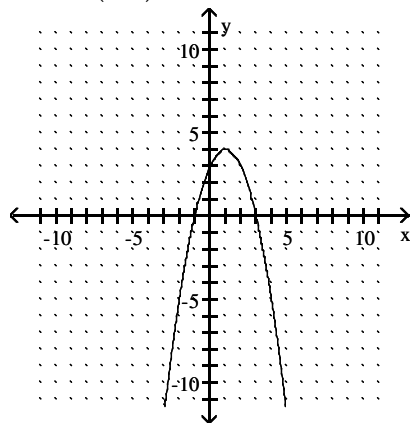

9) domain: all real numbers  
range:  $y \geq -1$

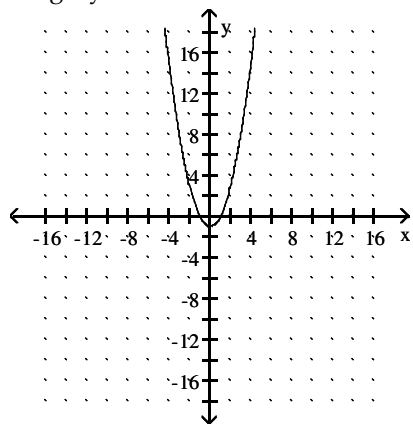

# Answer Key

Testname: QUIZ 7PREPARATION CH 7.1, 7.2, & 7.3V02

10) domain: all real numbers

range:  $y \geq 1$

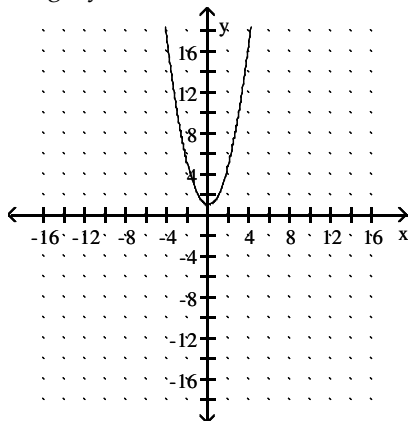

11) domain: all real numbers

range:  $y \geq 3$

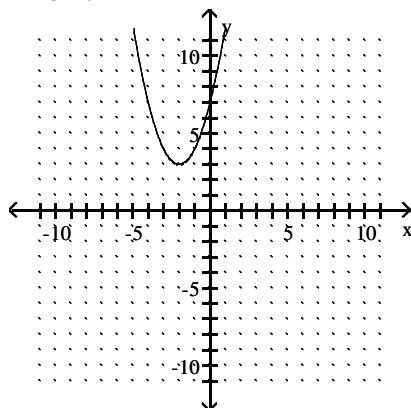

12) domain: all real numbers

range:  $y \leq 3$

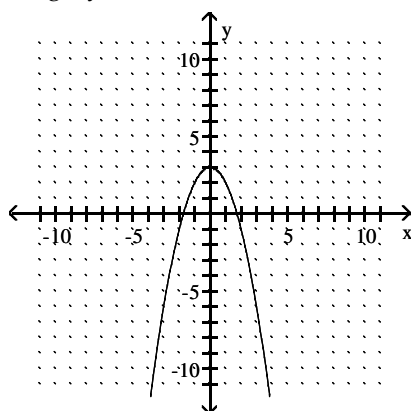

13)  $f(x) = (x + 2)^2 + 2$

14)  $f(x) = (x + 2)^2 - 2$

15)  $f(x) = (x - 3)^2 + 3$

16)  $f(x) = (x - 2)^2 - 2$

# Answer Key

Testname: QUIZ 7PREPARATION CH 7.1, 7.2, & 7.3V02

- 17) vertex  $(1, -9)$ ;  
x-int:  $(-2, 0)$  and  $(4, 0)$ ;  
y-int:  $(0, -8)$

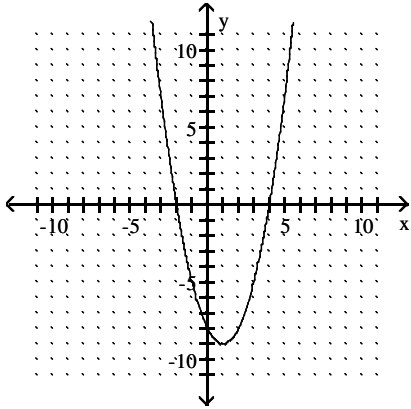

- 18) vertex  $(-1, 10)$ ;  
x-int:  $(0, 0)$  and  $(-2, 0)$ ;  
y-int:  $(0, 0)$

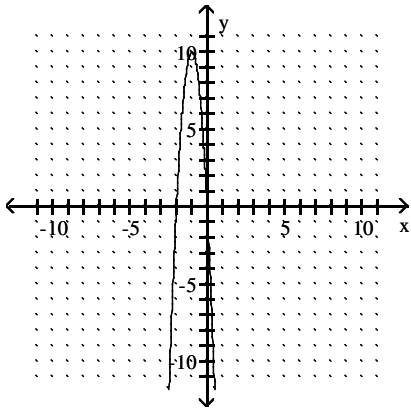

- 19) vertex  $(-2, 0)$ ;  
x-int:  $(-2, 0)$ ;  
y-int:  $(0, -4)$

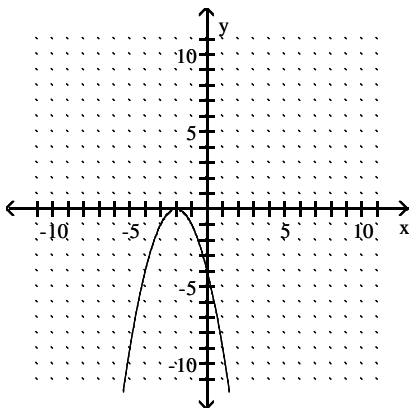

## Answer Key

Testname: QUIZ 7PREPARATION CH 7.1, 7.2, & 7.3V02

- 20) vertex  $(0, -64)$   
x-int:  $(-8, 0)$  and  $(8, 0)$   
y-int:  $(0, -64)$

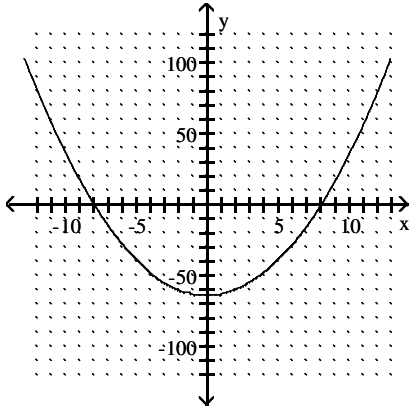

- 21) 39 ft  
22) 4.5 sec  
23)  $8450 \text{ ft}^2$   
24) 4.5 in.  
25) 4 thousand automobiles  
26) 5 thousand automobiles  
27) 26 cakes  
28) \$3671  
29)  $\frac{10}{9}$   
30)  $\frac{\sqrt{26}}{13}$   
31)  $\frac{2\sqrt{5}}{17}$   
32)  $\frac{\sqrt{5}}{6}$   
33)  $\frac{5\sqrt{2}}{2}$   
34)  $-5 \pm \sqrt{2}$   
35) -1, 13  
36) -3, 6  
37)  $-3 \pm 2\sqrt{6}$   
38)  $\frac{-3 \pm \sqrt{5}}{2}$   
39) 8, -3  
40)  $\frac{-3 \pm \sqrt{7}}{2}$   
41)  $\frac{5 \pm 9\sqrt{5}}{5}$   
42) 4, -10  
43) 3, -11  
44) 3, -11

## Answer Key

Testname: QUIZ 7PREPARATION CH 7.1, 7.2, & 7.3V02

$$45) \frac{2}{3}, \frac{1}{3}$$

$$46) \pm 5i$$

$$47) \pm 9i$$

$$48) \pm \frac{7i\sqrt{3}}{3}$$

$$49) 12 - 5i, 12 + 5i$$

$$50) \frac{-5 \pm i\sqrt{6}}{4}$$

$$51) \frac{5 \pm 6i\sqrt{5}}{5}$$